

MAMMOTH FANS

— CONTROL BOX DRIVER QUICK START GUIDE —



Exclusively distributed by Beacon Lighting



1 Quick Guide	
1.1 Safety	2
1.2 Introduction	3
1.2.1 Purpose of the Manual	3
1.2.2 Additional Resources	3
1.2.3 IT Mains	3
1.2.4 Avoid Unintended Start	7
1.3 Installation	4
1.3.1 Side-by-side Installation	4
1.3.2 Mechanical Dimensions	5
1.3.3 Connecting to Mains and Motor	7
1.3.4 Control Terminals	7
1.3.5 Power Circuit - Overview	9
1.3.6 Load Sharing/Brake	10
1.4 Programming	10
1.4.1 Programming on Automatic Motor Adaptation (AMA)	10
1.4.2 Programming on Automatic Motor Tuning (AMT)	10
1.5 Parameter Overview	12
1.6 Troubleshooting	16
1.7 Specifications	18
1.8 General Technical Data	22
1.9 Special Conditions	25
1.9.1 Derating for Ambient Temperature	25
1.9.2 Derating for Low Air Pressure	25
1.9.3 Derating for Running at Low Speeds	25
1.10 Options and Spare Parts	26
Index	27

1 Quick Guide

1.1 Safety

⚠ WARNING

HIGH VOLTAGE

Frequency converters contain high voltage when connected to AC mains input, DC supply, or load sharing. Failure to perform installation, start-up, and maintenance by qualified personnel can result in death or serious injury.

- Only qualified personnel must perform installation, start-up, and maintenance.

⚠ WARNING

UNINTENDED START

When the frequency converter is connected to AC mains, the motor may start at any time, causing risk of death, serious injury, equipment, or property damage. The motor can start by means of an external switch, a fieldbus command, an input reference signal from the LCP or LOP, or after a cleared fault condition.

- Disconnect the frequency converter from mains whenever personal safety considerations make it necessary to avoid unintended motor start.
- Press [Off/Reset] on the LCP before programming parameters.
- The frequency converter, motor, and any driven equipment must be in operational readiness when the frequency converter is connected to AC mains.

NOTICE

The [Off/Reset] key is not a safety switch. It does not disconnect the frequency converter from mains.

⚠ WARNING

DISCHARGE TIME

The frequency converter contains DC-link capacitors, which can remain charged even when the frequency converter is not powered. High voltage can be present even when the warning LED indicator lights are off. Failure to wait the specified time after power has been removed before performing service or repair work can result in death or serious injury.

- Stop the motor.
- Disconnect AC mains and remote DC-link power supplies, including battery back-ups, UPS, and DC-link connections to other frequency converters.
- Disconnect or lock PM motor.
- Wait for the capacitors to discharge fully. The minimum duration of waiting time is specified in *Table 1.1*.
- Before performing any service or repair work, use an appropriate voltage measuring device to make sure that the capacitors are fully discharged.

Size	Minimum waiting time (minutes)
M1, M2, and M3	4
M4 and M5	15

Table 1.1 Discharge Time

Leakage current (>3.5 mA)

Follow national and local codes regarding protective earthing of equipment with a leakage current >3,5 mA. Frequency converter technology implies high frequency switching at high power. This generates a leakage current in the ground connection. A fault current in the frequency converter at the output power terminals might contain a DC component, which can charge the filter capacitors and cause a transient ground current. The ground leakage current depends on various system configurations including RFI filtering, screened motor cables, and frequency converter power.

EN/IEC61800-5-1 (Power Drive System Product Standard) requires special care if the leakage current exceeds 3.5 mA. Reinforce Grounding in 1 of the following ways:

- Grounding wire of at least 10 mm².
- 2 separate ground wires both complying with the dimensioning rules.

See EN 60364-5-54 § 543.7 for further information.

Using RCDs

Where residual current devices (RCDs), also known as earth leakage circuit breakers (ELCBs), are used, comply with the following:

- Use RCDs of type B that can detect AC and DC currents.
- Use RCDs with an inrush delay to prevent faults due to transient ground currents.
- Dimension RCDs according to the system configuration and environmental considerations.

Motor thermal protection

Motor overload protection is possible by setting *1-90 Motor Thermal Protection* to [4] *ETR trip*. For the North American market: Implemented ETR function provides class 20 motor overload protection, in accordance with NEC.

Installation at high altitudes

For altitudes above 2000 m, contact Mammoth support regarding PELV.

1.1.1 Safety Instructions

- Make sure that the frequency converter is properly grounded.
- Do not remove mains connections, motor connections, or other power connections while the frequency converter is connected to power.
- Protect users against supply voltage.
- Protect the motor against overloading according to national and local regulations.
- The ground leakage current exceeds 3.5 mA. Ground the frequency converter properly.
- The [Off/Reset] key is not a safety switch. It does not disconnect the frequency converter from mains.

1.2 Introduction

1.2.1 Purpose of the Manual

These operating instructions provide information for safe installation and commissioning of the VLT® Micro Drive FC 51 frequency converter.

The operating instructions are intended for use by qualified personnel.

To use the frequency converter safely and professionally, read and follow the operating instructions. Pay particular attention to the safety instructions and general warnings. Always keep these operating instructions with the frequency converter.

VLT® is a registered trademark.

1.2.2 Additional Resources

Additional resources are available to understand advanced frequency converter functions and programming:

- The *VLT® Micro Drive FC 51 Programming Guide* provides greater detail on working with parameters and many application examples.
- The *VLT® Micro Drive Design Guide* provides detailed information about capabilities and functionality to design motor control systems.
- Instructions for operation with optional equipment, and replacement of components.

Supplementary publications and manuals are available from the suppliers website:

vlt-drives.danfoss.com/Support/Technical-Documentation/

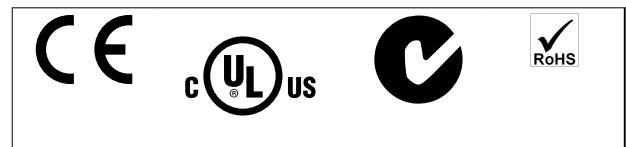

The frequency converter complies with UL 508C thermal memory retention requirements. For more information, refer to the section *Motor Thermal Protection* in the product-specific *design guide*.

1.2.3 IT Mains

NOTICE

IT MAINS

Installation on isolated mains source, that is IT mains. Maximum supply voltage allowed when connected to mains: 440 V.

As an option, recommended line filters for improved harmonics performance are available. *Table 1.10*

1.2.4 Avoid Unintended Start

While the frequency converter is connected to mains, the motor can be started/stopped using digital commands, bus commands, references, or via the LCP (local control panel). To avoid unintended start:

- Disconnect the frequency converter from mains for personal safety considerations.
- Always press [Off/Reset] before changing parameters.



Equipment containing electrical components must not be disposed of together with domestic waste.

It must be separately collected with electrical and electronic waste according to local and currently valid legislation.

1.3 Installation

1. Disconnect the FC 51 from mains (and external DC supply, if present).
2. Wait for 4 minutes (M1, M2, and M3) and 15 minutes (M4 and M5) for discharge of the DC-link. See *Table 1.1*.
3. Disconnect the DC bus terminals and the brake terminals (if present).
4. Remove the motor cable.

1.3.1 Side-by-side Installation

The frequency converter can be mounted side-by-side for IP20 rating units and requires 100 mm clearance above and below for cooling. Refer to *chapter 1.7 Specifications* for details on environmental ratings of the frequency converter.

1.3.2 Mechanical Dimensions

A template for drilling is found on the flap of the packaging.

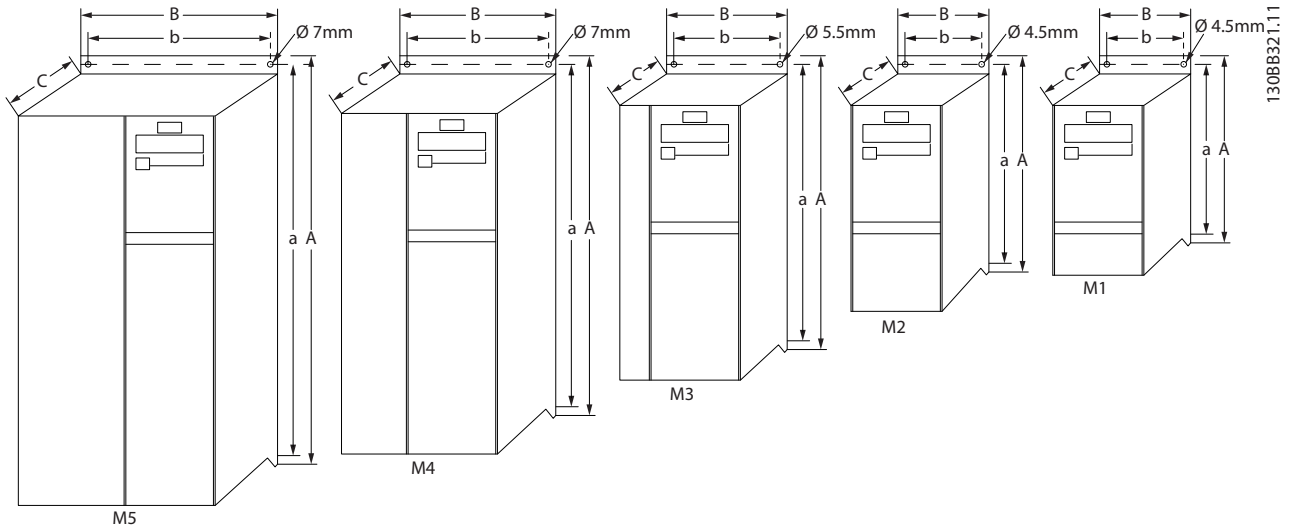

Enclosure	Power [kW]			Height [mm]			Width [mm]		Depth ¹⁾ [mm]	Maximum weight [kg]
	1x200-240 V	3x200-240 V	3x380-480 V	A	A (including decoupling plate)	a	B	b	C	
M1	0.18-0.75	0.25-0.75	0.37-0.75	150	205	140.4	70	55	148	1.1
M2	1.5	1.5	1.5-2.2	176	230	166.4	75	59	168	1.6
M3	2.2	2.2-3.7	3.0-7.5	239	294	226	90	69	194	3.0
M4			11.0-15.0	292	347.5	272.4	125	97	241	6.0
M5			18.5-22.0	335	387.5	315	165	140	248	9.5

1) For LCP with potentiometer, add 7.6 mm.

Illustration 1.1 Mechanical Dimensions

NOTICE

All cabling must comply with national and local regulations on cable cross-sections and ambient temperature. Copper conductors required, (60-75 °C) recommended.

Enclosure	Power [kW]			Torque [Nm]					
	1x200-240 V	3x200-240 V	3x380-480 V	Line	Motor	DC connection/brake	Control terminals	Ground	Relay
M1	0.18-0.75	0.25-0.75	0.37-0.75	0.8	0.7	Spade ¹⁾	0.15	3	0.5
M2	1.5	1.5	1.5-2.2	0.8	0.7	Spade ¹⁾	0.15	3	0.5
M3	2.2	2.2-3.7	3.0-7.5	0.8	0.7	Spade ¹⁾	0.15	3	0.5
M4	-	-	11.0-15.0	1.3	1.3	1.3	0.15	3	0.5
M5	-	-	18.5-22.0	1.3	1.3	1.3	0.15	3	0.5

1) Spade connectors (6.3 mm (0.25 in) Faston plugs)

Table 1.2 Tightening of Terminals

Branch circuit protection

To protect the installation against electrical and fire hazards, protect all branch circuits in an installation, switch gear, machines, and so on, against short circuits and overcurrent according to national/international regulations.

Short-circuit protection

Use the fuses mentioned in *Table 1.3* to protect service personnel or other equipment if there is an internal failure in the unit or short circuit on DC-link. If there is a short circuit on the motor or brake output, the frequency converter provides full short-circuit protection.

Overcurrent protection

To avoid overheating of the cables in the installation, provide overload protection. Always carry out overcurrent protection according to national regulations. Fuses must be

designed for protection in a circuit capable of supplying a maximum of 100000 A_{rms} (symmetrical), 480 V maximum.

Non-UL compliance

If UL/cUL is not to be complied with, use the fuses mentioned in *Table 1.3*, which ensure compliance with EN50178/IEC61800-5-1:

If there is a malfunction, not following the fuse recommendation may result in damage to the frequency converter and the installation.

FC 51	Maximum fuses UL						Maximum fuses non-UL
	Bussmann	Bussmann	Bussmann	Littelfuse	Ferraz Shawmut	Ferraz Shawmut	
1x200–240 V							
kW	Type RK1	Type J	Type T	Type RK1	Type CC	Type RK1	Type gG
0K18-0K37	KTN-R15	JKS-15	JJN-15	KLN-R15	ATM-R15	A2K-15R	16A
0K75	KTN-R25	JKS-25	JJN-25	KLN-R25	ATM-R25	A2K-25R	25A
1K5	KTN-R35	JKS-35	JJN-35	KLN-R35	–	A2K-35R	35A
2K2	KTN-R50	JKS-50	JJN-50	KLN-R50	–	A2K-50R	50A
3x200–240 V							
0K25	KTN-R10	JKS-10	JJN-10	KLN-R10	ATM-R10	A2K-10R	10A
0K37	KTN-R15	JKS-15	JJN-15	KLN-R15	ATM-R15	A2K-15R	16A
0K75	KTN-R20	JKS-20	JJN-20	KLN-R20	ATM-R20	A2K-20R	20A
1K5	KTN-R25	JKS-25	JJN-25	KLN-R25	ATM-R25	A2K-25R	25A
2K2	KTN-R40	JKS-40	JJN-40	KLN-R40	ATM-R40	A2K-40R	40A
3K7	KTN-R40	JKS-40	JJN-40	KLN-R40	–	A2K-40R	40A
3x380–480 V							
0K37-0K75	KTS-R10	JKS-10	JJS-10	KLS-R10	ATM-R10	A6K-10R	10A
1K5	KTS-R15	JKS-15	JJS-15	KLS-R15	ATM-R15	A2K-15R	16A
2K2	KTS-R20	JKS-20	JJS-20	KLS-R20	ATM-R20	A6K-20R	20A
3K0	KTS-R40	JKS-40	JJS-40	KLS-R40	ATM-R40	A6K-40R	40A
4K0	KTS-R40	JKS-40	JJS-40	KLS-R40	ATM-R40	A6K-40R	40A
5K5	KTS-R40	JKS-40	JJS-40	KLS-R40	–	A6K-40R	40A
7K5	KTS-R40	JKS-40	JJS-40	KLS-R40	–	A6K-40R	40A
11K0	KTS-R60	JKS-60	JJS-60	KLS-R60	–	A6K-60R	63A
15K0	KTS-R60	JKS-60	JJS-60	KLS-R60	–	A6K-60R	63A
18K5	KTS-R60	JKS-60	JJS-60	KLS-R60	–	A6K-60R	80A
22K0	KTS-R60	JKS-60	JJS-60	KLS-R60	–	A6K-60R	80A

Table 1.3 Fuses

1.3.3 Connecting to Mains and Motor

The frequency converter is designed to operate all standard 3-phased asynchronous motors. The frequency converter is designed to accept mains/ motor cables with a maximum cross-section of 4 mm²/10 AWG (M1, M2 and M3), and a maximum cross-section of 16 mm²/6 AWG (M4 and M5).

- Use a shielded/armoured motor cable to comply with EMC emission specifications, and connect this cable to both the decoupling plate and the motor metal.
- Keep motor cable as short as possible to reduce the noise level and leakage currents.
- For further details on mounting of the decoupling plate, see *VLT® Micro Drive FC 51 Decoupling Mounting Plate Instructions*.
- Also see the chapter *EMC-correct Electrical Installation* in the *VLT® Micro Drive FC 51 Design Guide*.

1. Mount the ground wires to PE terminal.
2. Connect motor to terminals U, V, and W.
3. Mount mains supply to terminals L1/L, L2, and L3/N (3-phase) or L1/L and L3/N (single-phase) and tighten.

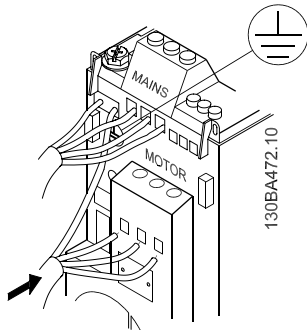

Illustration 1.2 Mounting of Ground Cable, Mains, and Motor Wires

1.3.4 Control Terminals

All control cable terminals are located underneath the terminal cover in front of the frequency converter. Remove the terminal cover using a screwdriver.

NOTICE

See the back of the terminal cover for outlines of control terminals and switches.

Do not operate switches with power on the frequency converter.

Set 6-19 Terminal 53 Mode according to Switch 4 position.

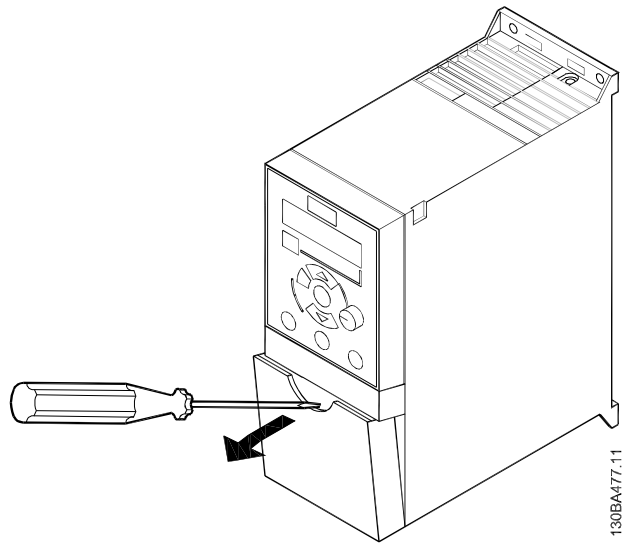

Illustration 1.3 Removing Terminal Cover

Switch 1	Off=PNP terminals 29 ¹⁾
	On=NPN terminals 29
Switch 2	Off=PNP terminal 18, 19, 27 and 33 ¹⁾
	On=NPN terminal 18, 19, 27 and 33
Switch 3	No function
Switch 4	Off=Terminal 53 0–10 V ¹⁾
	On=Terminal 53 0/4-20 mA
1)=default setting	

Table 1.4 Settings for S200 Switches 1–4

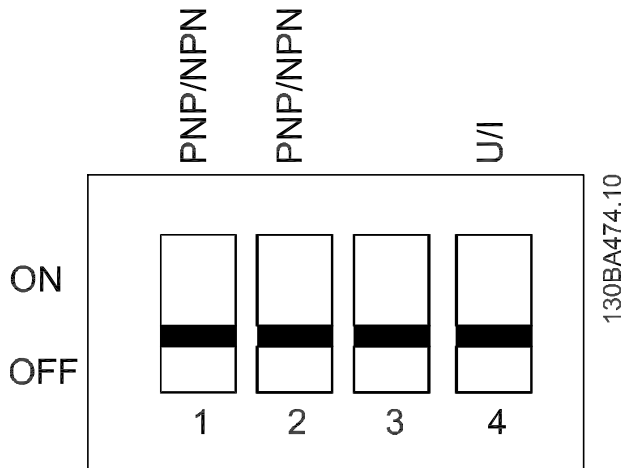

Illustration 1.4 S200 Switches 1–4

Illustration 1.5 shows all control terminals of the frequency converter. Applying Start (terminal 18) and an analog reference (terminal 53 or 60) make the frequency converter run.

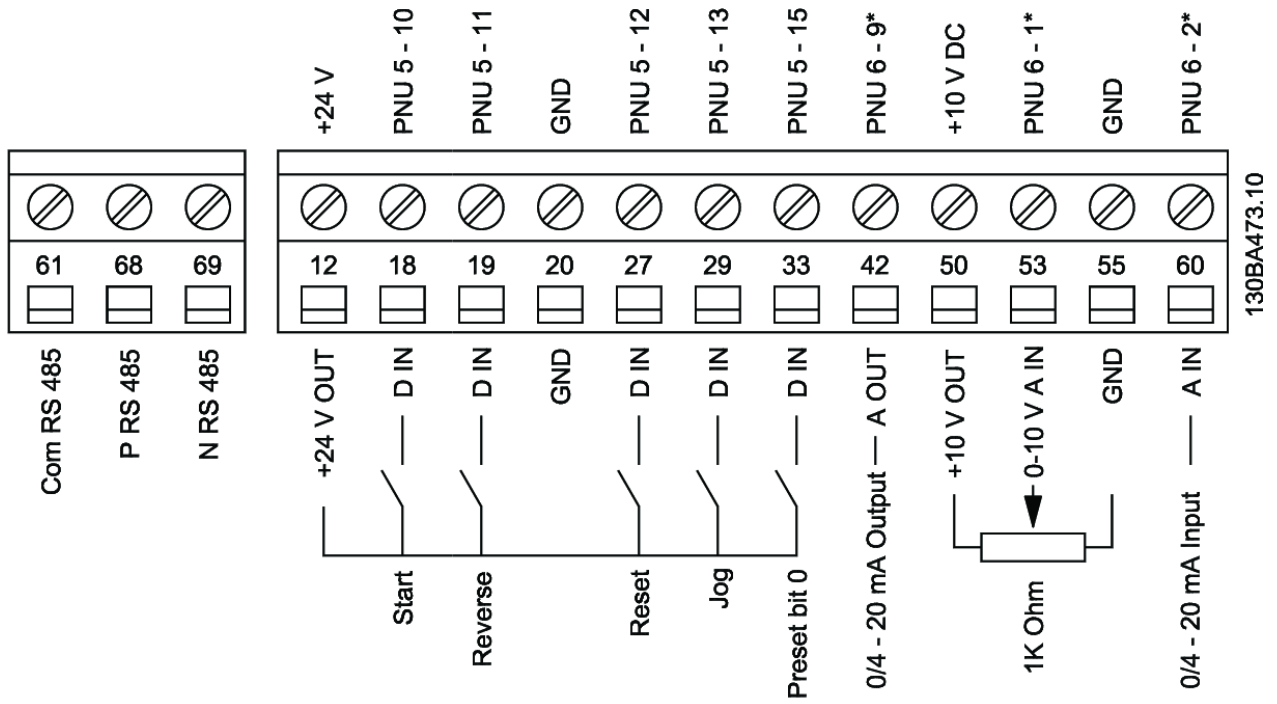

Illustration 1.5 Overview of Control Terminals in PNP-configuration with Factory Setting

1.3.5 Power Circuit - Overview

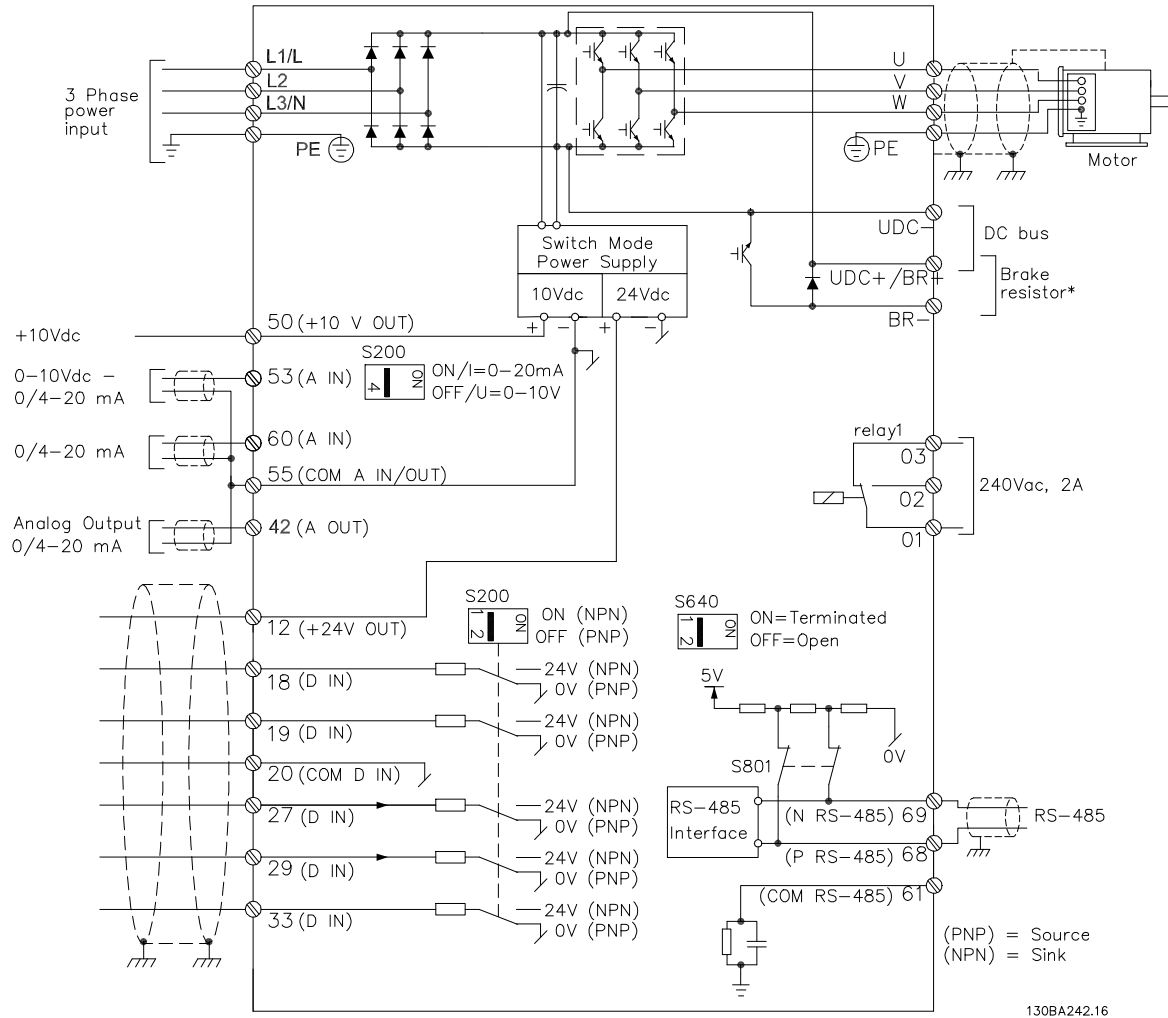

Illustration 1.6 Diagram Showing all Electrical Terminals

* Brakes (BR+ and BR-) are not applicable for enclosure size M1.

For information about brake resistors, see *VLT® Brake Resistor MCE 101 Design Guide*.

Improved power factor and EMC performance can be achieved by installing optional line filters.

Power filters can also be used for load sharing. For more information about load sharing, see *VLT® FC 51 Micro Drive Load Sharing* application note.

1.3.6 Load Sharing/Brake

Use 6.3 mm insulated Faston plugs designed for high voltage for DC (load sharing and brake).

Contact Mammoth support or see *Load sharing instruction VLT® 5000* for load sharing and *VLT® 2800/5000/5000 FLUX/FCD 300 Brake* for brake.

Load sharing

Connect terminals -UDC and +UDC/+BR.

Brake

Connect terminals -BR and +UDC/+BR (not applicable for enclosure size M1).

NOTICE

Voltage levels of up to 850 V DC may occur between terminals +UDC/+BR and -UDC. Not short circuit protected.

1.4 Programming

1.4.1 Programming on Automatic Motor Adaptation (AMA)

For detailed information on programming, see *VLT® Micro Drive FC 51 Programming Guide*.

NOTICE

The frequency converter can also be programmed from a PC via RS485 com-port by installing the MCT 10 Set-up Software.

This software can either be ordered using code number 130B1000 or downloaded from the suppliers web site: www.danfoss.com/BusinessAreas/DrivesSolutions/software-download

Press [Menu] to select 1 of the following menus:

Status

For readouts only.

Quick Menu

For access to Quick Menus 1 and 2.

Main Menu

For access to all parameters.

Navigation keys

[Back]: For moving to the previous step or layer in the navigation structure.

[▲] [▼]: For manoeuvring between parameter groups, parameters and within parameters.

[OK]: For selecting a parameter and for accepting changes to parameter settings.

Pressing [OK] for more than 1 s enters *Adjust* mode. In *Adjust* mode, it is possible to make fast adjustment by pressing [▲] [▼] combined with [OK].

Press [▲] [▼] to change value. Press [OK] to shift between digits quickly.

To exit *Adjust* mode, press [OK] more than 1 s again with changes saving or press [Back] without changes saving.

Operation keys

A yellow indicator light above the operation keys indicates the active key.

[Hand On]: Starts the motor and enables control of the frequency converter via the LCP.

[Off/Reset]: The motor stops. If in alarm mode, the motor resets.

[Auto On]: The frequency converter is controlled either via control terminals or serial communication.

[Potentiometer] (LCP12): The potentiometer works in 2 ways depending on the mode in which the frequency converter is running.

In *Auto On* mode, the potentiometer acts as an extra programmable analog input.

In *Hand On* mode, the potentiometer controls local reference.

1.4.2 Programming on Automatic Motor Tuning (AMT)

Run AMT to optimise compatibility between the frequency converter and the motor in VVC⁺ mode.

- The frequency converter builds a mathematical model of the motor for regulating output motor current thus enhancing motor performance.
- Run this procedure on a cold motor for best results. To run AMT, use the numeric LCP (NLCP). There are 2 AMT modes for frequency converters.

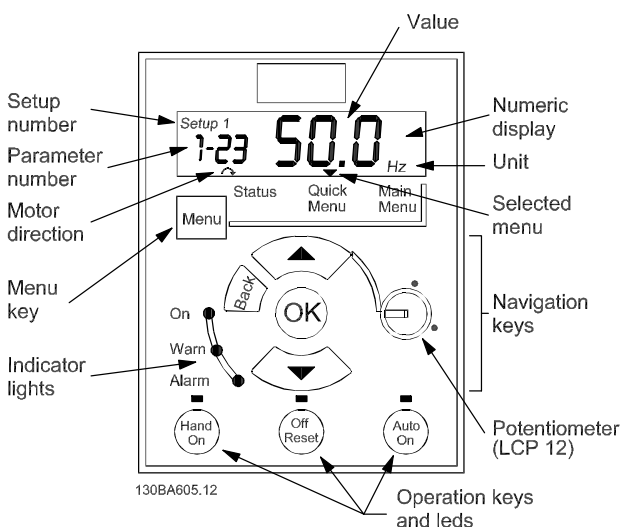

Illustration 1.7 Description of LCP Keys and Display

Mode 1

1. Enter the main menu.
 2. Go to parameter group 1-** *Load and Motor*.
 3. Press [OK].
 4. Set motor parameters using nameplate data for parameter group 1-2* *Motor Data*.
 5. Go to 1-29 *Automatic Motor Tuning (AMT)*.
 6. Press [OK].
 7. Select [2] *Enable AMT*.
 8. Press [OK].
 9. The test runs automatically and indicates when it is complete.
3. Press [OK].
 4. Set motor parameters using nameplate data for parameter group 1-2* *Motor Data*.
 5. Go to 1-29 *Automatic Motor Tuning (AMT)*.
 6. Press [OK].
 7. Select [3] *Complete AMT with Rotating motor*.
 8. Press [OK].
 9. The test runs automatically and indicates when it is complete.

NOTICE

In mode 2, the rotor rotates during the AMT progress. Do not add any load on motor in this AMT progress.

Mode 2

1. Enter the main menu.
2. Go to parameter group 1-** *Load and Motor*.

1.5 Parameter Overview

<p>0-** Operation/Display</p> <p>0-0* Basic Settings</p> <p>0-03 Regional Settings</p> <p>*[0] International</p> <p>[1] US</p> <p>0-04 Oper. State at Power-up (Hand)</p> <p>[0] Resume</p> <p>*[1] Forced stop, ref=old</p> <p>[2] Forced stop, ref=0</p> <p>0-1* Set-up Handling</p> <p>0-10 Active Set-up</p> <p>*[1] Set-up 1</p> <p>[2] Set-up 2</p> <p>[9] Multi Set-up</p> <p>0-11 Edit Set-up</p> <p>*[1] Set-up 1</p> <p>[2] Set-up 2</p> <p>[9] Active Set-up</p> <p>0-12 Link Set-ups</p> <p>[0] Not Linked</p> <p>*[20] Linked</p> <p>0-31 Custom Readout Min Scale</p> <p>0.00–9999.00 * 0.00</p> <p>0-32 Custom Readout Max Scale</p> <p>0.00–9999.00 * 100.0</p> <p>0-4* LCP Keypad</p> <p>0-40 [Hand on] Key on LCP</p> <p>[0] Disabled</p> <p>*[1] Enabled</p> <p>0-41 [Off / Reset] Key on LCP</p> <p>[0] Disable All</p> <p>*[1] Enable All</p> <p>[2] Enable Reset Only</p> <p>0-42 [Auto on] Key on LCP</p> <p>[0] Disabled</p> <p>*[1] Enabled</p> <p>0-5* Copy/Save</p> <p>0-50 LCP Copy</p> <p>*[0] No copy</p> <p>[1] All to LCP</p> <p>[2] All from LCP</p> <p>[3] Size indep. from LCP</p> <p>0-51 Set-up Copy</p> <p>*[0] No copy</p> <p>[1] Copy from set-up 1</p> <p>[2] Copy from set-up 2</p> <p>[9] Copy from Factory set-up</p> <p>0-6* Password</p> <p>0-60 (Main) Menu Password</p> <p>0–999 *0</p>	<p>0-61 Access to Main/Quick Menu w/o Password</p> <p>*[0] Full access</p> <p>[1] LCP:Read Only</p> <p>[2] LCP:No Access</p> <p>1-** Load/Motor</p> <p>1-0* General Settings</p> <p>1-00 Configuration Mode</p> <p>*[0] Speed open loop</p> <p>[3] Process</p> <p>1-01 Motor Control Principle</p> <p>[0] U/f</p> <p>*[1] VVC+</p> <p>1-03 Torque Characteristics</p> <p>*[0] Constant torque</p> <p>[2] Automatic Energy Optim.</p> <p>1-05 Local Mode Configuration</p> <p>[0] Speed Open Loop</p> <p>*[2] As config in par. 1-00</p> <p>1-2* Motor Data</p> <p>1-20 Motor Power [kW] [hp]</p> <p>[1] 0.09 kW/0.12 hp</p> <p>[2] 0.12 kW/0.16 hp</p> <p>[3] 0.18 kW/0.25 hp</p> <p>[4] 0.25 kW/0.33 hp</p> <p>[5] 0.37 kW/0.50 hp</p> <p>[6] 0.55 kW/0.75 hp</p> <p>[7] 0.75 kW/1.00 hp</p> <p>[8] 1.10 kW/1.50 hp</p> <p>[9] 1.50 kW/2.00 hp</p> <p>[10] 2.20 kW/3.00 hp</p> <p>[11] 3.00 kW/4.00 hp</p> <p>[12] 3.70 kW/5.00 hp</p> <p>[13] 4.00 kW/5.40 hp</p> <p>[14] 5.50 kW/7.50 hp</p> <p>[15] 7.50 kW/10.00 hp</p> <p>[16] 11.00 kW/15.00 hp</p> <p>[17] 15.00 kW/20.00 hp</p> <p>[18] 18.50 kW/25.00 hp</p> <p>[19] 22.00 kW/29.50 hp</p> <p>[20] 30.00 kW/40.00 hp</p> <p>1-22 Motor Voltage</p> <p>50–999 V *230–400 V</p> <p>1-23 Motor Frequency</p> <p>20–400 Hz *50 Hz</p> <p>1-24 Motor Current</p> <p>0.01–100.00 A *Motortype dep.</p> <p>1-25 Motor Nominal Speed</p> <p>100–9999 rpm *Motortype dep.</p>	<p>1-29 Automatic Motor Tuning (AMT)</p> <p>*[0] Off</p> <p>[2] Enable AMT</p> <p>[3] Complete AMT with Rotating motor</p> <p>1-3* Adv. Motor Data</p> <p>1-30 Stator Resistance (Rs)</p> <p>[Ohm] * Dep. on motor data</p> <p>1-33 Stator Leakage Reactance (X1)</p> <p>[Ohm] * Dep. on motor data</p> <p>1-35 Main Reactance (Xh)</p> <p>[Ohm] * Dep. on motor data</p> <p>1-5* Load Indep. Setting</p> <p>1-50 Motor Magnetisation at 0 Speed</p> <p>0–300% *100%</p> <p>1-52 Min Speed Norm. Magnet. [Hz]</p> <p>0.0–10.0 Hz *0.0Hz</p> <p>1-55 U/f Characteristic - U</p> <p>0–999.9 V</p> <p>1-56 U/f Characteristic - F</p> <p>0–400 Hz</p> <p>1-6* Load Depen. Setting</p> <p>1-60 Low Speed Load Compensation</p> <p>0–199% *100%</p> <p>1-61 High Speed Load Compensation</p> <p>0–199% *100%</p> <p>1-62 Slip Compensation</p> <p>–400–399% *100%</p> <p>1-63 Slip Compensation Time Constant</p> <p>0.05–5.00 s *0.10 s</p> <p>1-7* Start Adjustments</p> <p>1-71 Start Delay</p> <p>0.0–10.0 s *0.0 s</p> <p>1-72 Start Function</p> <p>[0] DC hold/delay time</p> <p>[1] DC brake/delay time</p> <p>*[2] Coast/delay time</p> <p>1-73 Flying Start</p> <p>*[0] Disabled</p> <p>[1] Enabled</p> <p>1-8* Stop Adjustments</p> <p>1-80 Function at Stop</p> <p>*[0] Coast</p> <p>[1] DC hold</p>	<p>1-82 Min Speed for Funct. at Stop [Hz]</p> <p>0.0–20.0 Hz *0.0 Hz</p> <p>1-9*Motor Temperature</p> <p>1-90 Motor Thermal Protection</p> <p>*[0] No protection</p> <p>[1] Thermistor warning</p> <p>[2] Thermistor trip</p> <p>[3] Etr warning</p> <p>[4] Etr trip</p> <p>1-93 Thermistor Resource</p> <p>*[0] None</p> <p>[1] Analog input 53</p> <p>[6] Digital input 29</p> <p>2-** Brakes</p> <p>2-0* DC-Brake</p> <p>2-00 DC Hold Current</p> <p>0–150% *50%</p> <p>2-01 DC Brake Current</p> <p>0–150% *50%</p> <p>2-02 DC Braking Time</p> <p>0.0–60.0 s *10.0 s</p> <p>2-04 DC Brake Cut In Speed</p> <p>0.0–400.0 Hz *0.0Hz</p> <p>2-1* Brake Energy Funct.</p> <p>2-10 Brake Function</p> <p>*[0] Off</p> <p>[1] Resistor brake</p> <p>[2] AC brake</p> <p>2-11 Brake Resistor (ohm)</p> <p>Min/Max/default: Powersize dep.</p> <p>2-14 Brake Voltage reduce</p> <p>0 - Powersize dep.* 0</p> <p>2-16 AC Brake, Max current</p> <p>0–150% *100%</p> <p>2-17 Overvoltage Control</p> <p>*[0] Disabled</p> <p>[1] Enabled (not at stop)</p> <p>[2] Enabled</p> <p>2-2* Mechanical Brake</p> <p>2-20 Release Brake Current</p> <p>0.00–100.0 A *0.00 A</p> <p>2-22 Activate Brake Speed [Hz]</p> <p>0.0–400.0 Hz *0.0 Hz</p> <p>3-** Reference / Ramps</p> <p>3-0* Reference Limits</p> <p>3-00 Reference Range</p> <p>*[0] Min - Max</p> <p>[1] -Max - +Max</p> <p>3-02 Minimum Reference</p> <p>–4999–4999 *0.000</p> <p>3-03 Maximum Reference</p> <p>–4999–4999 *50.00</p>
1) M4 and M5 only			

<p>3-1* References</p> <p>3-10 Preset Reference -100.0–100.0% *0.00% 3-11 Jog Speed [Hz] 0.0–400.0 Hz *5.0 Hz</p> <p>3-12 Catch up/slow Down Value 0.00–100.0% * 0.00%</p> <p>3-14 Preset Relative Reference -100.0–100.0% *0.00%</p> <p>3-15 Reference Resource 1 [0] No function *[1] Analog Input 53 [2] Analog input 60 [8] Pulse input 33 [11] Local bus ref [21] LCP Potentiometer</p> <p>3-16 Reference Resource 2 [0] No function [1] Analog in 53 *[2] Analog in 60 [8] Pulse input 33 *[11] Local bus reference [21] LCP Potentiometer</p> <p>3-17 Reference Resource 3 [0] No function [1] Analog Input 53 [2] Analog input 60 [8] Pulse input 33 *[11] Local bus ref [21] LCP Potentiometer</p> <p>3-18 Relative Scaling Ref. Resource *[0] No function [1] Analog Input 53 [2] Analog input 60 [8] Pulse input 33 [11] Local bus ref [21] LCP Potentiometer</p> <p>3-4* Ramp 1</p> <p>3-40 Ramp 1 Type *[0] Linear [2] Sine2 ramp</p> <p>3-41 Ramp 1 Ramp up Time 0.05–3600 s *3.00 s (10.00 s¹)</p> <p>3-42 Ramp 1 Ramp Down Time 0.05–3600 s *3.00s (10.00s¹)</p> <p>3-5* Ramp 2</p> <p>3-50 Ramp 2 Type *[0] Linear [2] Sine2 ramp</p> <p>3-51 Ramp 2 Ramp up Time 0.05–3600 s *3.00 s (10.00 s¹)</p> <p>3-52 Ramp 2 Ramp down Time 0.05–3600 s *3.00 s (10.00 s¹)</p> <p>3-8* Other Ramps</p> <p>3-80 Jog Ramp Time 0.05–3600 s *3.00 s (10.00s¹)</p>	<p>3-81 Quick Stop Ramp Time 0.05–3600 s *3.00 s (10.00s¹)</p> <p>4-** Limits/Warnings</p> <p>4-1* Motor Limits 4-10 Motor Speed Direction *[0] Clockwise If Par. 1-00 is set to close loop control [1] CounterClockwise *[2] Both if Par. 1-00 is set to open loop control</p> <p>4-12 Motor Speed Low Limit [Hz] 0.0–400.0 Hz *0.0 Hz</p> <p>4-14 Motor Speed High Limit [Hz] 0.1–400.0 Hz *65.0 Hz</p> <p>4-16 Torque Limit Motor Mode 0–400% *150%</p> <p>4-17 Torque Limit Generator Mode 0–400% *100%</p> <p>4-4* Adj. Warnings 2</p> <p>4-40 Warning Frequency Low 0.00–Value of 4-41 Hz *0.0 Hz</p> <p>4-41 Warning Frequency High Value of 4-40–400.0 Hz *400.00 Hz</p> <p>4-5* Adj. Warnings</p> <p>4-50 Warning Current Low 0.00–100.00 A *0.00 A</p> <p>4-51 Warning Current High 0.0–100.00 A *100.00 A</p> <p>4-54 Warning Reference Low -4999.000–Value of 4-55 * -4999.000</p> <p>4-55 Warning Reference High Value of 4-54–4999.000 *4999.000</p> <p>4-56 Warning Feedback Low -4999.000–Value of 4-57 * -4999.000</p> <p>4-57 Warning Feedback High Value of 4-56–4999.000 *4999.000</p> <p>4-58 Missing Motor Phase Function [0] Off *[1] On</p> <p>4-6* Speed Bypass</p> <p>4-61 Bypass Speed From [Hz] 0.0–400.0 Hz *0.0 Hz</p> <p>4-63 Bypass Speed To [Hz] 0.0–400.0 Hz *0.0 Hz</p>	<p>5-1* Digital Inputs 5-10 Terminal 18 Digital Input [0] No function [1] Reset [2] Coast inverse [3] Coast and reset inv. [4] Quick stop inverse [5] DC-brake inv. [6] Stop inv *[8] Start [9] Latched start [10] Reversing [11] Start reversing [12] Enable start forward [13] Enable start reverse [14] Jog [16-18] Preset ref bit 0-2 [19] Freeze reference</p> <p>5-10 Terminal 18 Digital Input [20] Freeze output [21] Speed up [22] Speed down [23] Set-up select bit 0 [28] Catch up [29] Slow down [34] Ramp bit 0 [60] Counter A (up) [61] Counter A (down) [62] Reset counter A [63] Counter B (up) [64] Counter B (down) [65] Reset counter B</p> <p>5-11 Terminal 19 Digital Input See par. 5-10. * [10] Reversing</p> <p>5-12 Terminal 27 Digital Input See par. 5-10. * [1] Reset</p> <p>5-13 Terminal 29 Digital Input See par. 5-10. * [14] Jog</p> <p>5-15 Terminal 33 Digital Input See par. 5-10. * [16] Preset ref bit 0 [26] Precise Stop Inverse [27] Start, Precise Stop [32] Pulse Input</p> <p>5-3* Digital Outputs</p> <p>5-34 On Delay, Terminal 42 Digital Output 0.00–600.00 s * 0.01 s</p> <p>5-35 Off Delay, Terminal 42 Digital Output 0.00–600.00 s * 0.01 s</p> <p>5-4* Relays</p>	<p>5-40 Function Relay [52] Remote ref. active [53] No alarm [54] Start cmd active [55] Running reverse [56] Drive in hand mode [57] Drive in auto mode [60-63] Comparator 0-3 [70-73] Logic rule 0-3 [81] SL digital output B</p> <p>5-41 On Delay, Relay 0.00–600.00 s *0.01 s</p> <p>5-42 Off Delay, Relay 0.00–600.00 s *0.01 s</p> <p>5-5* Pulse Input</p> <p>5-55 Terminal 33 Low Frequency 20–4999 Hz *20 Hz</p> <p>5-56 Terminal 33 High Frequency 21–5000 Hz *5000 Hz</p> <p>5-57 Term. 33 Low Ref./Feedb. Value -4999–4999 *0.000</p> <p>5-58 Term. 33 High Ref./Feedb. Value -4999–4999 *50.000</p> <p>6-** Analog In/Out</p> <p>6-0* Analog I/O Mode</p> <p>6-00 Live Zero Timeout Time 1-99 s *10 s</p> <p>6-01 Live Zero TimeoutFunction *[0] Off [1] Freeze output [2] Stop [3] Jogging [4] Max speed [5] Stop and trip</p> <p>6-1* Analog Input 1</p> <p>6-10 Terminal 53 Low Voltage 0.00–9.99 V *0.07 V</p> <p>6-11 Terminal 53 High Voltage 0.01–10.00 V *10.00 V</p> <p>6-12 Terminal 53 Low Current 0.00–19.99 mA *0.14 mA</p> <p>6-13 Terminal 53 High Current 0.01–20.00 mA *20.00 mA</p> <p>6-14 Term. 53 Low Ref./Feedb. Value -4999–4999 *0.000</p> <p>6-15 Term. 53 High Ref./Feedb. Value -4999–4999 *50.000</p> <p>6-16 Terminal 53 Filter Time Constant 0.01–10.00 s *0.01 s</p>
<p>1) M4 and M5 only</p>			

<p>6-19 Terminal 53 mode *[0] Voltage mode [1] Current mode 4</p> <p>6-2* Analog Input 2</p> <p>6-22 Terminal 60 Low Current 0.00–19.99 mA *0.14 mA</p> <p>6-23 Terminal 60 High Current 0.01–20.00 mA *20.00 mA</p> <p>6-24 Term. 60 Low Ref./Feedb. Value –4999–4999 *0.000</p> <p>6-25 Term. 60 High Ref./Feedb. Value –4999–4999 *50.00</p> <p>6-26 Terminal 60 Filter Time Constant 0.01–10.00 s *0.01 s</p> <p>6-8* LCP Potentiometer</p> <p>6-80 LCP Potmeter Enable [0] Disabled *[1] Enable</p> <p>6-81 LCP potm. Low Reference –4999–4999 *0.000</p> <p>6-82 LCP potm. High Reference –4999–4999 *50.00</p> <p>6-9* Analog Output xx</p> <p>6-90 Terminal 42 Mode *[0] 0–20 mA [1] 4–20 mA [2] Digital Output</p> <p>6-91 Terminal 42 Analog Output *[0] No operation [10] Output Frequency [11] Reference [12] Feedback [13] Motor Current [16] Power [19] DC Link Voltage [20] Bus Reference</p> <p>6-92 Terminal 42 Digital Output See parameter 5-40 *[0] No Operation [80] SL Digital Output A</p> <p>6-93 Terminal 42 Output Min Scale 0.00–200.0% *0.00%</p> <p>6-94 Terminal 42 Output Max Scale 0.00–200.0% *100.0%</p> <p>7-** Controllers</p> <p>7-2* Process Ctrl. Feedb</p> <p>7-20 Process CL Feedback 1 Resource *[0] NoFunction [1] Analog Input 53 [2] Analog input 60 [8] PulseInput33 [11] LocalBusRef</p> <p>7-3* Process PI</p>	<p>Ctrl. 7-30 Process PI Normal/ Inverse Ctrl *[0] Normal [1] Inverse</p> <p>7-31 Process PI Anti Windup [0] Disable *[1] Enable</p> <p>7-32 Process PI Start Speed 0.0–200.0 Hz *0.0 Hz</p> <p>7-33 Process PI Proportional Gain 0.00–10.00 *0.01</p> <p>7-34 Process PI Integral Time 0.10–9999 s *9999 s</p> <p>7-38 Process PI Feed Forward Factor 0–400% *0%</p> <p>7-39 On Reference Bandwidth 0–200% *5%</p> <p>8-** Comm. and Options</p> <p>8-0* General Settings</p> <p>8-01 Control Site *[0] Digital and ControlWord [1] Digital only [2] ControlWord only</p> <p>8-02 Control Word Source [0] None *[1] FC RS485</p> <p>8-03 Control Word Timeout Time 0.1–6500 s *1.0 s</p> <p>8-04 Control Word Timeout Function *[0] Off [1] Freeze Output [2] Stop [3] Jogging [4] Max. Speed [5] Stop and trip</p> <p>8-06 Reset Control Word Timeout *[0] No Function [1] Do reset</p> <p>8-3* FC Port Settings</p> <p>8-30 Protocol *[0] FC [2] Modbus</p> <p>8-31 Address 1–247 *1</p> <p>8-32 FC Port Baud Rate [0] 2400 Baud [1] 4800 Baud *[2] 9600 Baud For choose FC Bus in 8-30 *[3] 19200 Baud For choose Modbus in 8-30 [4] 38400 Baud</p>	<p>8-33 FC Port Parity *[0] Even Parity, 1 Stop Bit [1] Odd Parity, 1 Stop Bit [2] No Parity, 1 Stop Bit [3] No Parity, 2 Stop Bits</p> <p>8-35 Minimum Response Delay 0.001–0.5 *0.010 s</p> <p>8-36 Max Response Delay 0.100–10.00 s *5.000 s</p> <p>8-4* FC MC protocol set</p> <p>8-43 FC Port PCD Read Configuration *[0] None Expressionlimit [1] [1500] Operation Hours [2] [1501] Running Hours [3] [1502] kWh Counter [4] [1600] Control Word [5] [1601] Reference [Unit] [6] [1602] Reference % [7] [1603] Status Word [8] [1605] Main Actual Value [%] [9] [1609] Custom Readout [10] [1610] Power [kW] [11] [1611] Power [hp] [12] [1612] Motor Voltage [13] [1613] Frequency [14] [1614] Motor Current [15] [1615] Frequency [%] [16] [1618] Motor Thermal [17] [1630] DC Link Voltage [18] [1634] Heatsink Temp. [19] [1635] Inverter Thermal [20] [1638] SL Controller State [21] [1650] External Reference [22] [1651] Pulse Reference [23] [1652] Feedback [Unit] [24] [1660] Digital Input 18,19,27,33 [25] [1661] Digital Input 29 [26] [1662] Analog Input 53 (V) [27] [1663] Analog Input 53 (mA) [28] [1664] Analog Input 60 [29] [1665] Analog Output 42 [mA] [30] [1668] Freq. Input 33 [Hz] [31] [1671] Relay Output [bin] [32] [1672] Counter A [33] [1673] Counter B [34] [1690] Alarm Word [35] [1692] Warning Word [36] [1694] Ext. Status Word</p> <p>8-5* Digital/Bus</p> <p>8-50 Coasting Select [0] DigitalInput [1] Bus [2] LogicAnd *[3] LogicOr</p> <p>8-51 Quick Stop Select See par. 8-50 * [3] LogicOr</p>	<p>8-52 DC Brake Select See par. 8-50 *[3] LogicOr</p> <p>8-53 Start Select See par. 8-50 *[3] LogicOr</p> <p>8-54 Reversing Select See par. 8-50 *[3] LogicOr</p> <p>8-55 Set-up Select See par. 8-50 *[3] LogicOr</p> <p>8-56 Preset Reference Select See parameter 8-50 * [3] LogicOr</p> <p>8-8* Bus communication Diagnostics</p> <p>8-80 Bus Message Count 0-0 N/A *0 N/A</p> <p>8-81 Bus Error Count 0-0 N/A *0 N/A</p> <p>8-82 Slave Messages Rcvd 0-0 N/A *0 N/A</p> <p>8-83 Slave Error Count 0-0 N/A *0 N/A</p> <p>8-9* Bus Jog / Feedback</p> <p>8-94 Bus feedback 1 0x8000-0x7FFF *0</p> <p>13-** Smart Logic</p> <p>13-0* SLC Settings</p> <p>13-00 SL Controller Mode *[0] Off [1] On</p> <p>13-01 Start Event [0] False [1] True [2] Running [3] InRange [4] OnReference [7] OutOfCurrentRange [8] BelowLow [9] AboveHigh [16] ThermalWarning [17] MainOutOfRange [18] Reversing [19] Warning [20] Alarm_Trip [21] Alarm_TripLock [22-25] Comparator 0-3 [26-29] LogicRule0-3 [33] DigitalInput_18 [34] DigitalInput_19 [35] DigitalInput_27 [36] DigitalInput_29 [38] DigitalInput_33 *[39] StartCommand [40] DriveStopped</p> <p>13-02 Stop Event See parameter 13-01 * [40] DriveStopped</p> <p>13-03 Reset SLC *[0] Do not reset [1] Reset SLC</p>
---	---	---	--

<p>13-1* Comparators</p> <p>13-10 Comparator Operand</p> <p>*[0] Disabled</p> <p>[1] Reference</p> <p>[2] Feedback</p> <p>[3] MotorSpeed</p> <p>[4] MotorCurrent</p> <p>[6] MotorPower</p> <p>[7] MotorVoltage</p> <p>[8] DCLinkVoltage</p> <p>[12] AnalogInput53</p> <p>[13] AnalogInput60</p> <p>[18] PulseInput33</p> <p>[20] AlarmNumber</p> <p>[30] CounterA</p> <p>[31] CounterB</p> <p>13-11 Comparator Operator</p> <p>[0] Less Than</p> <p>*[1] Approximately equals</p> <p>[2] Greater Than</p> <p>13-12 Comparator Value</p> <p>-9999-9999 *0.0</p> <p>13-2* Timers</p> <p>13-20 SL Controller Timer</p> <p>0.0-3600 s *0.0 s</p> <p>13-4* Logic Rules</p> <p>13-40 Logic Rule Boolean 1</p> <p>See par. 13-01 *[0] False</p> <p>[30] - [32] SL Time-out 0-2</p> <p>13-41 Logic Rule Operator 1</p> <p>*[0] Disabled</p> <p>[1] And</p> <p>[2] Or</p> <p>[3] And not</p> <p>[4] Or not</p> <p>[5] Not and</p> <p>[6] Not or</p> <p>[7] Not and not</p> <p>[8] Not or not</p> <p>13-42 Logic Rule Boolean 2</p> <p>See par. 13-40 * [0] False</p> <p>13-43 Logic Rule Operator 2</p> <p>See par. 13-41 *[0] Disabled</p> <p>13-44 Logic Rule Boolean 3</p> <p>See par. 13-40 * [0] False</p> <p>13-5* States</p> <p>13-51 SL Controller Event</p> <p>See par. 13-40 *[0] False</p>	<p>13-52 SL Controller Action</p> <p>*[0] Disabled</p> <p>[1] NoAction</p> <p>[2] SelectSetup1</p> <p>[3] SelectSetup2</p> <p>[10-17] SelectPresetRef0-7</p> <p>[18] SelectRamp1</p> <p>[19] SelectRamp2</p> <p>[22] Run</p> <p>[23] RunReverse</p> <p>[24] Stop</p> <p>[25] Qstop</p> <p>[26] DCstop</p> <p>[27] Coast</p> <p>[28] FreezeOutput</p> <p>[29] StartTimer0</p> <p>[30] StartTimer1</p> <p>[31] StartTimer2</p> <p>[32] Set Digital Output A Low</p> <p>[33] Set Digital Output B Low</p> <p>[38] Set Digital Output A High</p> <p>[39] Set Digital Output B High</p> <p>[60] ResetCounterA</p> <p>[61] ResetCounterB</p> <p>14-** Special Functions</p> <p>14-0* Inverter Switching</p> <p>14-01 Switching Frequency</p> <p>[0] 2 kHz</p> <p>*[1] 4 kHz</p> <p>[2] 8 kHz</p> <p>[4] 16 kHz not available for M5</p> <p>14-03 Overmodulation</p> <p>[0] Off</p> <p>*[1] On</p> <p>14-1* Mains monitoring</p> <p>14-12 Function at mains imbalance</p> <p>*[0] Trip</p> <p>[1] Warning</p> <p>[2] Disabled</p> <p>14-2* Trip Reset</p> <p>14-20 Reset Mode</p> <p>*[0] Manual reset</p> <p>[1-9] AutoReset 1-9</p> <p>[10] AutoReset 10</p> <p>[11] AutoReset 15</p> <p>[12] AutoReset 20</p> <p>[13] Infinite auto reset</p> <p>[14] Reset at power up</p> <p>14-21 Automatic Restart Time</p> <p>0-600s * 10s</p>	<p>14-22 Operation Mode</p> <p>*[0] Normal Operation</p> <p>[2] Initialisation</p> <p>14-26 Action At Inverter Fault</p> <p>*[0] Trip</p> <p>[1] Warning</p> <p>14-4* Energy Optimising</p> <p>14-41 AEO Minimum Magnetisation</p> <p>40-75 %*66 %</p> <p>14-9* Fault Settings</p> <p>14-90 Fault level[3] Trip Lock</p> <p>[4] Trip with delayed reset</p> <p>15-** Drive Information</p> <p>15-0* Operating Data</p> <p>15-00 Operating Days</p> <p>15-01 Running Hours</p> <p>15-02 kWh Counter</p> <p>15-03 Power Ups</p> <p>15-04 Over Temps</p> <p>15-05 Over Volts</p> <p>15-06 Reset kWh Counter</p> <p>*[0] Do not reset</p> <p>[1] Reset counter</p> <p>15-07 Reset Running Hours Counter</p> <p>*[0] Do not reset</p> <p>[1] Reset counter</p> <p>15-3* Fault Log</p> <p>15-30 Fault Log: Error Code</p> <p>15-4* Drive Identification</p> <p>15-40 FC Type</p> <p>15-41 Power Section</p> <p>15-42 Voltage</p> <p>15-43 Software Version</p> <p>15-46 Frequency Converter Order. No</p> <p>15-48 LCP Id No</p> <p>15-51 Frequency Converter Serial No</p> <p>16-** Data Readouts 16-0* General Status</p> <p>16-00 Control Word</p> <p>0-0XFFFF</p> <p>16-01 Reference [Unit]</p> <p>-4999-4999 *0.000</p> <p>16-02 Reference %</p> <p>-200.0-200.0% *0.0%</p> <p>16-03 Status Word</p> <p>0-0XFFFF</p> <p>16-05 Main Actual Value [%]</p> <p>-200.0-200.0% *0.0%</p>	<p>16-09 Custom Readout</p> <p>Dep. on par. 0-31, 0-32</p> <p>16-1* Motor Status</p> <p>16-10 Power [kW]</p> <p>16-11 Power [hp]</p> <p>16-12 Motor Voltage [V]</p> <p>16-13 Frequency [Hz]</p> <p>16-14 Motor Current [A]</p> <p>16-15 Frequency [%]</p> <p>16-18 Motor Thermal [%]</p> <p>16-3* Drive Status</p> <p>16-30 DC Link Voltage</p> <p>16-34 Heat sink Temp.</p> <p>16-35 Inverter Thermal</p> <p>16-36 Inv.Nom. Current</p> <p>16-37 Inv. Max. Current</p> <p>16-38 SL Controller State</p> <p>16-5* Ref./Feedb.</p> <p>16-50 External Reference</p> <p>16-51 Pulse Reference</p> <p>16-52 Feedback [Unit]</p> <p>16-6* Inputs/Outputs</p> <p>16-60 Digital Input 18,19,27,33</p> <p>0-1111</p> <p>16-61 Digital Input 29</p> <p>0-1</p> <p>16-62 Analog Input 53 (volt)</p> <p>16-63 Analog Input 53 (current)</p> <p>16-64 Analog Input 60</p> <p>16-65 Analog Output 42 [mA]</p> <p>16-68 Pulse Input [Hz]</p> <p>16-71 Relay Output [bin]</p> <p>16-72 Counter A</p> <p>16-73 Counter B</p> <p>16-8* Fieldbus/FC Port</p> <p>16-86 FC Port REF 1</p> <p>0x8000-0x7FFFF</p> <p>16-9* Diagnosis Readouts</p> <p>16-90 Alarm Word</p> <p>0-0XFFFFFF</p> <p>16-92 Warning Word</p> <p>0-0XFFFFFF</p> <p>16-94 Ext. Status Word</p> <p>0-0XFFFFFF</p> <p>18-** Extended Motor Data</p> <p>18-8* Motor Resistors</p> <p>18-80 Stator Resistance (High resolution)</p> <p>0.000-99.990 ohm *0.000 ohm</p> <p>18-81 Stator Leakage Reactance(High resolution)</p> <p>0.000-99.990 ohm *0.000 ohm</p>
--	---	---	--

1.6 Troubleshooting

1.6.1 Warnings and Alarms

Number	Description	Warning	Alarm	Trip Lock	Error	Cause of problem
2	Live zero error	X	X			Signal on terminal 53 or 60 is less than 50% of the value set in: <ul style="list-style-type: none"> • <i>parameter 6-10 Terminal 53 Low Voltage</i> • <i>parameter 6-12 Terminal 53 Low Current</i> • <i>parameter 6-22 Terminal 54 Low Current</i>
4	Mains phase loss ¹⁾	X	X	X		Missing phase on supply side, or too high voltage imbalance. Check supply voltage.
7	DC over voltage ¹⁾	X	X			DC-link voltage exceeds the limit.
8	DC under voltage ¹⁾	X	X			DC-link voltage drops below the voltage warning limit.
9	Inverter overloaded	X	X			More than 100% load for too long.
10	Motor ETR overtemperature	X	X			Motor is too hot. The load has exceeded 100% for too long.
11	Motor thermistor overtemperature	X	X			Thermistor or thermistor connection is disconnected.
12	Torque limit	X				Torque exceeds value set in either parameter <i>4-16 Torque Limit Motor Mode</i> or <i>4-17 Torque Limit Generator Mode</i> .
13	Overcurrent	X	X	X		Inverter peak current limit is exceeded.
14	Ground fault	X	X	X		Discharge from output phases to ground.
16	Short Circuit		X	X		Short circuit in motor or on motor terminals.
17	Control word time-out	X	X			No communication to frequency converter.
25	Brake resistor short-circuited		X	X		Brake resistor is short-circuited, thus the brake function is disconnected.
27	Brake chopper short-circuited		X	X		Brake transistor is short-circuited, thus the brake function is disconnected.
28	Brake check		X			Brake resistor is not connected/working.
29	Power board over temp	X	X	X		Heat sink cut-out temperature has been reached.
30	Motor phase U missing		X	X		Motor phase U is missing. Check the phase.
31	Motor phase V missing		X	X		Motor phase V is missing. Check the phase.
32	Motor phase W missing		X	X		Motor phase W is missing. Check the phase.
38	Internal fault		X	X		Contact Mammoth support
44	Ground fault		X	X		Discharge from output phases to ground.
47	Control Voltage Fault		X	X		24 V DC is overloaded.
51	AMA check U_{nom} and I_{nom}		X			Wrong setting for motor voltage and/or motor current.
52	AMA low I_{nom}		X			Motor current is too low. Check settings.
59	Current limit	X				Frequency converter overload.
63	Mechanical Brake Low		X			Actual motor current has not exceeded the release brake-current within the start delay-time window.
80	Frequency Converter Initialised to Default Value		X			All parameter settings are initialised to default settings.
84	The connection between frequency converter and LCP is lost				X	No communication between LCP and frequency converter.
85	Key disabled				X	See parameter group <i>0-4* LCP</i> .
86	Copy fail				X	An error occurred while copying from frequency converter to LCP, or from LCP to frequency converter.
87	LCP data invalid				X	Occurs when copying from LCP if the LCP contains erroneous data - or if no data was uploaded to the LCP.

Quick Guide

88	LCP data not compatible				X	Occurs when copying from LCP if data are moved between frequency converters with major differences in software versions.
89	Parameter read only				X	Occurs when trying to write to a read-only parameter.
90	Parameter database busy				X	LCP and RS485 connection are trying to update parameters simultaneously.
91	Parameter value is not valid in this mode				X	Occurs when trying to write an illegal value to a parameter.
92	Parameter value exceeds the min/max limits				X	Occurs when trying to set a value outside the range.
nw run	Not While Runnin				X	Parameters can only be changed when the motor is stopped.
Err.	A wrong password was entered				X	Occurs when using a wrong password for changing a password-protected parameter.
1) These faults are caused by mains distortions. Install a line filter to rectify this problem.						

Table 1.5 Warnings and Alarms Code List

1.7 Specifications

1.7.1 Mains Supply 1x200–240 V AC

Normal overload 150% for 1 minute					
Frequency converter	PK18	PK37	PK75	P1K5	P2K2
Typical shaft output [kW]	0.18	0.37	0.75	1.5	2.2
Typical shaft output [hp]	0.25	0.5	1	2	3
Enclosure protection rating IP20	M1	M1	M1	M2	M3
Output current					
Continuous (1x200–240 V AC) [A]	1.2	2.2	4.2	6.8	9.6
Intermittent (1x200–240 V AC) [A]	1.8	3.3	6.3	10.2	14.4
Maximum cable size:					
(Mains, motor) [mm ² /AWG]	4/10				
Maximum input current					
Continuous (1x200–240 V) [A]	3.3	6.1	11.6	18.7	26.4
Intermittent (1x200–240 V) [A]	4.5	8.3	15.6	26.4	37.0
Maximum mains fuses [A]	See chapter 1.3.3 Fuses				
Environment					
Estimated power loss [W], Best case/typical ¹⁾	12.5/ 15.5	20.0/ 25.0	36.5/ 44.0	61.0/ 67.0	81.0/ 85.1
Weight enclosure IP20 [kg]	1.1	1.1	1.1	1.6	3.0
Efficiency [%], Best case/typical ²⁾	95.6/ 94.5	96.5/ 95.6	96.6/ 96.0	97.0/ 96.7	96.9/ 97.1

Table 1.6 Mains Supply 1x200–240 V AC

1) Applies for dimensioning of frequency converter cooling. If the switching frequency is higher than the default setting, the power losses may increase. LCP and typical control card power consumptions are included. For power loss data according to EN 50598-2, refer to www.danfoss.com/vltenergyefficiency.

2) Efficiency measured at nominal current. For energy efficiency class, see chapter 1.8.1 Surroundings. For part load losses, see www.danfoss.com/vltenergyefficiency.

1.7.2 Mains Supply 3x200–240 V AC

Normal overload 150% for 1 minute						
Frequency converter	PK25	PK37	PK75	P1K5	P2K2	P3K7
Typical shaft output [kW]	0.25	0.37	0.75	1.5	2.2	3.7
Typical shaft output [hp]	0.33	0.5	1	2	3	5
Enclosure protection rating IP20	M1	M1	M1	M2	M3	M3
Output current						
Continuous (3x200–240 V) [A]	1.5	2.2	4.2	6.8	9.6	15.2
Intermittent (3x200–240 V) [A]	2.3	3.3	6.3	10.2	14.4	22.8
Maximum cable size:						
(Mains, motor) [mm ² /AWG]	4/10					
Maximum input current						
Continuous (3x200–240 V) [A]	2.4	3.5	6.7	10.9	15.4	24.3
Intermittent (3x200–240 V) [A]	3.2	4.6	8.3	14.4	23.4	35.3
Maximum mains fuses [A]	See chapter 1.3.3 Fuses					
Environment						
Estimated power loss [W]	14.0/ 20.0	19.0/ 24.0	31.5/ 39.5	51.0/ 57.0	72.0/ 77.1	115.0/ 122.8
Weight enclosure IP20 [kg]	1.1	1.1	1.1	1.6	3.0	3.0
Efficiency [%]	96.4/ 94.9	96.7/ 95.8	97.1/ 96.3	97.4/ 97.2	97.2/ 97.4	97.3/ 97.4

Table 1.7 Mains Supply 3x200–240 V AC

1) Applies for dimensioning of frequency converter cooling. If the switching frequency is higher than the default setting, the power losses may increase. LCP and typical control card power consumptions are included. For power loss data according to EN 50598-2, refer to www.danfoss.com/vltenergyefficiency.

2) Efficiency measured at nominal current. For energy efficiency class, see chapter 1.8.1 Surroundings. For part load losses, see www.danfoss.com/vltenergyefficiency.

1.7.3 Mains Supply 3x380–480 V AC

Normal overload 150% for 1 minute						
Frequency converter	PK37	PK75	P1K5	P2K2	P3K0	P4K0
Typical shaft output [kW]	0.37	0.75	1.5	2.2	3.0	4.0
Typical shaft output [hp]	0.5	1	2	3	4	5.5
Enclosure protection rating IP20	M1	M1	M2	M2	M3	M3
Output current						
Continuous (3x380–440 V) [A]	1.2	2.2	3.7	5.3	7.2	9.0
Intermittent (3x380–440 V) [A]	1.8	3.3	5.6	8.0	10.8	13.7
Continuous (3x440–480 V) [A]	1.1	2.1	3.4	4.8	6.3	8.2
Intermittent (3x440–480 V) [A]	1.7	3.2	5.1	7.2	9.5	12.3
Maximum cable size:						
(Mains, motor) [mm ² /AWG]	4/10					
Maximum input current						
Continuous (3x380–440 V) [A]	1.9	3.5	5.9	8.5	11.5	14.4
Intermittent (3x380–440 V) [A]	2.6	4.7	8.7	12.6	16.8	20.2
Continuous (3x440–480 V) [A]	1.7	3.0	5.1	7.3	9.9	12.4
Intermittent (3x440–480 V) [A]	2.3	4.0	7.5	10.8	14.4	17.5
Maximum mains fuses [A]	See chapter 1.3.3 Fuses					
Environment						
Estimated power loss [W]	18.5/	28.5/	41.5/	57.5/	75.0/	98.5/
Best case/typical ¹⁾	25.5	43.5	56.5	81.5	101.6	133.5
Weight enclosure IP20 [kg]	1.1	1.1	1.6	1.6	3.0	3.0
Efficiency [%]	96.8/	97.4/	98.0/	97.9/	98.0/	98.0/
Best case/typical ²⁾	95.5	96.0	97.2	97.1	97.2	97.3

Table 1.8 Mains Supply 3x380–480 V AC

Quick Guide

Normal overload 150% for 1 minute						
Frequency converter	P5K5	P7K5	P11K	P15K	P18K	P22K
Typical shaft output [kW]	5.5	7.5	11	15	18.5	22
Typical shaft output [hp]	7.5	10	15	20	25	30
Enclosure protection rating IP20	M3	M3	M4	M4	M5	M5
Output current						
Continuous (3x380–440 V) [A]	12.0	15.5	23.0	31.0	37.0	43.0
Intermittent (3x380–440 V) [A]	18.0	23.5	34.5	46.5	55.5	64.5
Continuous (3x440–480 V) [A]	11.0	14.0	21.0	27.0	34.0	40.0
Intermittent (3x440–480 V) [A]	16.5	21.3	31.5	40.5	51.0	60.0
Maximum cable size:						
(Mains, motor) [mm ² /AWG]	4/10		16/6			
Maximum input current						
Continuous (3x380–440 V) [A]	19.2	24.8	33.0	42.0	34.7	41.2
Intermittent (3x380–440 V) [A]	27.4	36.3	47.5	60.0	49.0	57.6
Continuous (3x440–480 V) [A]	16.6	21.4	29.0	36.0	31.5	37.5
Intermittent (3x440–480 V) [A]	23.6	30.1	41.0	52.0	44.0	53.0
Maximum mains fuses [A]	See chapter 1.3.3 Fuses					
Environment						
Estimated power loss [W]	131.0/	175.0/	290.0/	387.0/	395.0/	467.0/
Best case/typical ¹⁾	166.8	217.5	342.0	454.0	428.0	520.0
Weight enclosure IP20 [kg]	3.0	3.0				
Efficiency [%]	98.0/	98.0/	97.8/	97.7/	98.1/	98.1/
Best case/typical ²⁾	97.5	97.5	97.4	97.4	98.0	97.9

Table 1.9 Mains Supply 3x380–480 V AC

1) Applies for dimensioning of frequency converter cooling. If the switching frequency is higher than the default setting, the power losses may increase. LCP and typical control card power consumptions are included. For power loss data according to EN 50598-2, refer to www.danfoss.com/vltenergyefficiency.

2) Efficiency measured at nominal current. For energy efficiency class, see chapter 1.8.1 Surroundings. For part load losses, see www.danfoss.com/vltenergyefficiency.

1.8 General Technical Data

Protection and features

- Electronic motor thermal protection against overload.
- Temperature monitoring of the heat sink ensures that the frequency converter trips if there is overtemperature.
- The frequency converter is protected against short circuits between motor terminals U, V, W.
- When a motor phase is missing, the frequency converter trips and issues an alarm.
- When a mains phase is missing, the frequency converter trips or issues a warning (depending on the load).
- Monitoring of the DC-link voltage ensures that the frequency converter trips when the DC-link voltage is too low or too high.
- The frequency converter is protected against ground faults on motor terminals U, V, W.

Mains supply (L1/L, L2, L3/N)

Supply voltage	200–240 V ±10%
Supply voltage	380–480 V ±10%
Supply frequency	50/60 Hz
Maximum imbalance temporary between mains phases	3.0% of rated supply voltage
True power factor	≥0.4 nominal at rated load
Displacement power factor (cosφ) near unity	(>0.98)
Switching on input supply L1/L, L2, L3/N (power-ups)	Maximum 2 times/minute
Environment according to EN60664-1	Overtoltage category III/pollution degree 2

The unit is suitable for use on a circuit capable of delivering not more than 100000 RMS symmetrical Amperes, 240/480 V maximum.

Motor output (U, V, W)

Output voltage	0–100% of supply voltage
Output frequency	0–200 Hz (VVC ⁺), 0–400 Hz (u/f)
Switching on output	Unlimited
Ramp times	0.05–3600 s

Cable length and cross-section

Maximum motor cable length, shielded/armored (EMC-correct installation)	15 m (49 ft)
Maximum motor cable length, unshielded/unarmored	50 m (164 ft)
Maximum cross-section to motor, mains ¹⁾	
Connection to load sharing/brake (M1, M2, M3)	6.3 mm insulated Faston plugs
Maximum cross-section to load sharing/brake (M4, M5)	16 mm ² /6 AWG
Maximum cross-section to control terminals, rigid wire	1.5 mm ² /16 AWG (2x0.75 mm ²)
Maximum cross-section to control terminals, flexible cable	1 mm ² /18 AWG
Maximum cross-section to control terminals, cable with enclosed core	0.5 mm ² /20 AWG
Minimum cross-section to control terminals	0.25 mm ² (24 AWG)

1) See chapter 1.7 Specifications for more information.

Digital inputs (pulse/encoder inputs)

Programmable digital inputs (pulse/encoder)	5 (1)
Terminal number	18, 19, 27, 29, 33
Logic	PNP or NPN
Voltage level	0–24 V DC
Voltage level, logic 0 PNP	<5 V DC
Voltage level, logic 1 PNP	>10 V DC
Voltage level, logic 0 NPN	>19 V DC
Voltage level, logic 1 NPN	<14 V DC
Maximum voltage on input	28 V DC
Input resistance, R _i	Approximately 4000 Ω
Maximum pulse frequency at terminal 33	5000 Hz

Quick Guide

Minimum pulse frequency at terminal 33 20 Hz

Analog inputs

Number of analog inputs	2
Terminal number	53, 60
Voltage mode (terminal 53)	Switch S200=OFF(U)
Current mode (terminal 53 and 60)	Switch S200=ON(I)
Voltage level	0–10 V
Input resistance, R_i	Approximately 10000 Ω
Maximum voltage	20 V
Current level	0/4 to 20 mA (scaleable)
Input resistance, R_i	Approximately 200 Ω
Maximum current	30 mA

Analog output

Number of programmable analog outputs	1
Terminal number	42
Current range at analog output	0/4–20 mA
Maximum load to common at analog output	500 Ω
Maximum voltage at analog output	17 V
Accuracy on analog output	Maximum error: 0.8% of full scale
Scan interval	4 ms
Resolution on analog output	8 bit
Scan interval	4 ms

Control card, RS485 serial communication

Terminal number	68 (P, TX+, RX+), 69 (N, TX-, RX-)
Terminal number 61	Common for terminals 68 and 69

Control card, 24 V DC output

Terminal number	12
Maximum load (M1 and M2)	100 mA
Maximum load (M3)	50 mA
Maximum load (M4 and M5)	80 mA

Relay output

Programmable relay output	1
Relay 01 terminal number	01-03 (break), 01-02 (make)
Maximum terminal load (AC-1) ¹⁾ on 01-02 (NO) (Resistive load)	250 V AC, 2 A
Maximum terminal load (AC-15) ¹⁾ on 01-02 (NO) (Inductive load @ $\cos\phi$ 0.4)	250 V AC, 0.2 A
Maximum terminal load (DC-1) ¹⁾ on 01-02 (NO) (Resistive load)	30 V DC, 2 A
Maximum terminal load (DC-13) ¹⁾ on 01-02 (NO) (Inductive load)	24 V DC, 0.1 A
Maximum terminal load (AC-1) ¹⁾ on 01-03 (NC) (Resistive load)	250 V AC, 2 A
Maximum terminal load (AC-15) ¹⁾ on 01-03 (NC) (Inductive load @ $\cos\phi$ 0.4)	250 V AC, 0.2 A
Maximum terminal load (DC-1) ¹⁾ on 01-03 (NC) (Resistive load)	30 V DC, 2 A
Minimum terminal load on 01-03 (NC), 01-02 (NO)	24 V DC 10 mA, 24 V AC 20 mA
Environment according to EN 60664-1	Overvoltage category III/pollution degree 2

1) IEC 60947 part 4 and 5

Control card, 10 V DC output

Terminal number	50
Output voltage	10.5 V \pm 0.5 V
Maximum load	25 mA

NOTICE

All inputs, outputs, circuits, DC supplies, and relay contacts are galvanically isolated from the supply voltage (PELV) and other high-voltage terminals.

Surroundings

Enclosure protection rating	IP20
Enclosure kit available	IP21, TYPE 1
Vibration test	1.0 g
Maximum relative humidity	5%–95 % (IEC 60721-3-3; Class 3K3 (non-condensing) during operation)
Aggressive environment (IEC 60721-3-3), coated	class 3C3
Test method according to IEC 60068-2-43 H2S (10 days)	
Ambient temperature ¹⁾	Maximum 40 °C (104 °F)
Minimum ambient temperature during full-scale operation	0 °C (32 °F)
Minimum ambient temperature at reduced performance	-10 °C (14 °F)
Temperature during storage/transport	-25 to +65/70 °C
Maximum altitude above sea level without derating ¹⁾	1000 m (3280 ft)
Maximum altitude above sea level with derating ¹⁾	3000 m (9842 ft)
Safety standards	EN/IEC 61800-5-1, UL 508C
EMC standards, Emission	EN 61800-3, EN 61000-6-3/4, EN 55011, IEC 61800-3 EN 61800-3, EN 61000-6-1/2, EN 61000-4-2, EN 61000-4-3,
EMC standards, Immunity	EN 61000-4-4, EN 61000-4-5, EN 61000-4-6
Energy efficiency class	IE2

1) Refer to chapter 1.9 Special Conditions for:

- Derating for high ambient temperature.
- Derating for high altitude.

2) Determined according to EN 50598-2 at:

- Rated load.
- 90% rated frequency.
- Switching frequency factory setting.
- Switching pattern factory setting.

1.9 Special Conditions

1.9.1 Derating for Ambient Temperature

The ambient temperature measured over 24 hours should be at least 5 °C lower than the maximum ambient temperature.

If the frequency converter is operated at high ambient temperature, decrease the continuous output current.

The frequency converter has been designed for operation at maximum 50 °C ambient temperature with 1 motor size smaller than nominal. Continuous operation at full load at 50 °C ambient temperature reduces the lifetime of the frequency converter.

1.9.2 Derating for Low Air Pressure

The cooling capability of air is decreased at low air pressure.



INSTALLATION AT HIGH ALTITUDE

For altitudes above 2000 m (6560 ft), contact Mammoth support regarding PELV.

Below 1000 m (3280 ft) altitude, no derating is necessary, but above 1000 m (3280 ft), decrease the ambient temperature or the maximum output current. Decrease the output by 1% per 100 m (328 ft) altitude above 1000 m (3280 ft), or reduce the maximum ambient temperature by 1 °C per 200 m (656 ft).

1.9.3 Derating for Running at Low Speeds

When a motor is connected to a frequency converter, check that the cooling of the motor is adequate. A problem may occur at low speeds in constant torque applications. Running continuously at low speeds – less than half the nominal motor speed – may require extra air cooling. Alternatively, select a larger motor (1 size up).

1.10 Options and Spare Parts

Ordering number	Description
132B0100	VLT Control Panel LCP 11 w/o potentiometer
132B0101	VLT Control Panel LCP 12 with potentiometer
132B0102	LCP Remote Mounting Kit , w/ 3m cable, IP55 with LCP 11, IP21 with LCP 12
132B0103	IP20 to NEMA Type 1 Conversion Kit, M1
132B0104	IP20 to NEMA Type 1 Conversion Kit, M2
132B0105	IP20 to NEMA Type 1 Conversion Kit, M3
132B0106	Decoupling Plate mounting kit, M1 and M2
132B0107	Decoupling Plate mounting kit, M3
132B0108	IP20 to IP21/Type1 conversion kit, M1
132B0109	IP20 to IP21/Type1 conversion kit, M2
132B0110	IP20 to IP21/Type1 conversion kit, M3
132B0111	DIN Rail Mounting Kit, M1/M2
132B0120	IP20 to Nema 1 Conversion Kit, M4
132B0121	IP20 to Nema 1 Conversion Kit, M5
132B0122	Decoupling Plate mounting kit, M4, M5
132B0126	Enclosure size M1 spare parts kits
132B0127	Enclosure size M2 spare parts kits
132B0128	Enclosure size M3 spare parts kits
132B0129	Enclosure size M4 spare parts kits
132B0130	Enclosure size M5 spare parts kits
132B0131	Blank cover
130B2522	MCC 107 filter for 132F0001
130B2522	MCC 107 filter for 132F0002
130B2533	MCC 107 filter for 132F0003
130B2525	MCC 107 filter for 132F0005
130B2530	MCC 107 filter for 132F0007
130B2523	MCC 107 filter for 132F0008
130B2523	MCC 107 filter for 132F0009
130B2523	MCC 107 filter for 132F0010
130B2526	MCC 107 filter for 132F0012
130B2531	MCC 107 filter for 132F0014
130B2527	MCC 107 filter for 132F0016
130B2523	MCC 107 filter for 132F0017
130B2523	MCC 107 filter for 132F0018
130B2524	MCC 107 filter for 132F0020
130B2526	MCC 107 filter for 132F0022
130B2529	MCC 107 filter for 132F0024
130B2531	MCC 107 filter for 132F0026
130B2528	MCC 107 filter for 132F0028
130B2527	MCC 107 filter for 132F0030

Table 1.10 Options and Spare Parts

Line filters and brake resistors are available upon request.

Index

A

Active set-up..... 12
 Ambient temperature..... 24
 Analog input..... 23

B

Brake resistor..... 12

C

Cable
 length and cross-section..... 18
 Clearance..... 4

D

DC brake..... 14
 Derating
 for ambient temperature..... 25
 for low air pressure..... 25
 for running at low speed..... 25
 Digital input..... 22
 Discharge time..... 2

E

Edit set-up..... 12
 Electronic waste..... 4
 Energy efficiency 18,19, 20, 21
 Energy efficiency class..... 24

G

Ground leakage current..... 3
 Ground wire..... 2
 Grounding..... 2

H

High voltage..... 2

I

Isolated mains source..... 3

L

Load compensation..... 12
 Load sharing..... 2, 10
 Local mode..... 14

M

Main menu..... 10
 Mains supply (L1/L, L2, L3/N)..... 22
 Mains supply 1x200–240 V AC..... 18
 Mains supply 3x200–240 V AC..... 19
 Mains supply 3x380–480 V AC..... 20
 Motor
 overload protection..... 3, 22
 phase..... 14
 temperature..... 12

N

Navigation key..... 10

O

Operation key..... 10
 Option and spart part..... 26
 Overcurrent protection..... 6
 Overvoltage control..... 12

P

Power circuit overview..... 9
 Protection..... 6

Index

R

RCD..... 3

S

Slip compensation..... 12

Status..... 10

T

Thermal protection..... 4

Thermistor..... 12

U

UL compliance..... 6

Unintended start..... 2

V

Voltage level..... 22

W

Warning and alarm..... 17



www.mammothfans.com.au